

POWER PRODUCTS MANUAL No. 375-905-2

TECHNICAL MANUAL
INSTRUMENT VERIFICATION PROCEDURE

HIGH RATE DISCHARGE TESTER

**POWER PRODUCTS INC.
P/N 37512 MODEL ST-375
NSN: 6625-01-539-5418**

MFD BY: POWER PRODUCTS INC
27 PAMARON WAY, BLDG. E
NOVATO, CA 94949
CAGE CODE: 3C8X4
www.power-products.com

TABLE OF CONTENTS

SECTION 1 INTRODUCTION AND DESCRIPTION	3
1.1 Introduction.....	3
1.2 Test Instrument (TI)-37512 Power	3
1.3 Test Malfunctions	3
Table 1 Verification Description	4
SECTION 2 EQUIPMENT REQUIREMENTS.....	4
Table 2 Equipment Requirements for TI	5
SECTION 3 PRELIMINARY OPERATIONS	5
3.1 Instructions.....	5
3.1.1 Operation.....	5
3.1.2 Battery Precaution.....	5
Table 3 Tolerance Limits	6
Figure 1 Voltmeter Test Setup.....	6
WARNING	6
SECTION 4 VERIFICATION PROCESS	6
4.1 Power Switch	6
AMMETER AND SHUNT TEST SETUP.....	7
Figure 2 Ammeter Test Setup.....	7
Figure 3 Timing Setup Test	8
Table 4 Timing Requirements	8
Summary Table of Tolerance Requirements	9
Parts List for Power Products ST-375 High Rate Discharge Tester.....	9

ILLUSTRATIONS

Figure	Page
1 Voltmeter Test Setup	6
2 Ammeter Test Setup	7
3 Timing Setup Test	8

TABLES

Table	Page
1 Verification Description	4
2 Equipment Requirements.....	5
3 Tolerance Limits	6
4 Timing Requirements	8
5 Summary Table of Tolerance Requirements.....	9

SECTION 1 INTRODUCTION AND DESCRIPTION

1.1 Introduction

The ST-375 (P/N 37512) High Rate Discharge Unit is for testing SLI (Starting, Lighting, Ignition) engine start batteries. It is powered only by the battery on test. It is used to accept or reject 12-Volt engine start batteries which have been fully charged. The ST-375 is designed to work on batteries that have CCA (Cold Cranking Amps) ratings in the approximate range of 700 CCA to 1,000 CCA. However, it will also accurately test batteries with a higher CCA rating such as those used in large commercial trucks and military tactical vehicles. The unit is essentially a SAE (Society of Automotive Engineers) tester which places a nominal 375 Ampere (at approximately 10.5 V) load on the battery for a period of 15 seconds. A digital voltmeter on the unit reads and holds the battery voltage at the end of 15 seconds. If the voltage is at or above 10.0 volts, the battery is ready for issue. If the voltage is below 10.0 volts the battery is rejected. The battery may be recharged for another test depending on circumstances such as if this were a first attempt to condition the rejected battery. The ST-375 has a high wattage resistive load bank. The resistors do not glow during the 15 second test. The control switch has an automatic position which is pressed, released, and tests for 15 seconds. A manual position can be pressed for less than 15 seconds. An internal 500 Ampere Shunt and panel ammeter has its test terminals (Kelvin Terminals) connected to a pair of test points on the front panel. The voltmeter also has test points. The ampere (current) reading may vary from battery to battery depending on the battery voltage under test and also on the time that has elapsed with previous use. The reading may be verified, iaw FIG.2.

1.2 Test Instrument (TI)-37512 Power

This procedure describes the verification of accuracy of Power Products High rate Discharger Tester P/N 37512. The 37512 being verified is referred to herein as the TI (Test Instrument). The TI operates from the battery being tested and does not require any other power.

1.3 Test Malfunctions

This procedure includes tests of essential performance parameters only. Any malfunction or out of limit Reading(s) noticed during these procedures, whether specifically tested for or not, should be referred to Power Products Inc.

Table 1 Verification Description (FIG. 1, 2, 3)

TI Characteristics	Performance Specification	Test Method
Voltmeter (FIG. 1)	Range: 0 to 13 V (Meter range 99.9 V) Tolerance: 0.2 V	Connect to battery or power supply, keep TI power switch OFF. Compare TI voltmeter reading with multi-meter.
Internal Shunt and Ammeter (NOTE: Shunt is 500Amp. 50 Millivolt) (FIG. 2)	Range: 0 to 38MV/380Amp Rating: 1.0 Millivolts/ 10 Amps Actual load tolerance is 375 Amps \pm 15 Amps at 10.5 Volts 10 Seconds of load (.028 Ohms at 10 Seconds)	Load the TI with a battery or high current 12 volt power supply. Use external shunt and 2 multi-meters. Compare TI ammeter reading with one multi-meter and with external shunt and second multi-meter.
Internal Timer (FIG. 3) Timer holds the voltmeter reading at the end of 15 second test.	TIME: tolerance 2 Seconds	Check with Quartz stop-watch or timer.

SECTION 2 EQUIPMENT REQUIREMENTS

NOTES

Minimum use specifications are the principal parameters required for performance of the verification, and are included to assist in the selection of alternate equipment, which may be used at the discretion of the using facility. Satisfactory performance of alternate items shall be verified prior to use. Timer or Stop watch can be verified with a known accurate timekeeper.

The instruments utilized in this procedure were selected from those known to be available at military facilities and the listing by make or model number carries no implication of preference, recommendation, or approval for use by other agencies. It is recognized that equivalent equipment produced by other manufacturers may be capable of equally satisfactory performance in this procedure.

Table 2 Equipment Requirements for TI

Item	Minimum Use Specifications	Verification Equipment
2.1 Two Digital multi-meters (DMM)	DC volts to 13V (2)DC millivolts to 40mV	FLUKE 77AN
2.2 Ammeter shunt 10 Amperes per Millivolt eg.500Amp 50mv or 1000Amp 100mv Shunt	Range: 0 to 50mV	Local Supply
2.3 Charged Optima battery or power supply capable of 400Amps 12.5V - 10V for 15 Seconds	NA	Local Supply
2.4 Timer	NA	Local Supply

SECTION 3 PRELIMINARY OPERATIONS

3.1 Instructions

A condensed version of the following instructions is located on the TI front panel.

Connect fully charged 12 volt battery – Red clamp to Positive terminal, Black clamp to Negative. Voltmeter will read battery Open Circuit Voltage. Ammeter reads discharge only when load test is in progress.

Battery voltage must be above 5 volts for voltmeter to display Open Circuit Voltage (OCV). Battery must be fully charged in order to test. Usually 12.7 – 13.0 OCV.

Select 375 amp switch position for Optima batteries. The 375 amp position may be used as a quick manual test to verify that the battery voltage does not collapse. If the voltmeter does not display battery voltage, verify that the battery has been charged.

3.1.1 Operation

- Press switch to “AUTO”, then release. This will start 15 second load test. At the end of 15 seconds the amber LED will light, and the voltmeter will hold the end-of-test voltage.
- If the end voltage is at or above 10.0 volts, the battery is acceptable. If test voltage is below 10.0 volts the battery is unacceptable. Before disposing of a failed battery recharge and retest a second time.
- If battery voltage falls below approximately 8 volts, auto timing is inoperative. Recharge battery and retest.
- Stop button may be used at any time. Auto or Manual switches are reset after the stop button is pressed and released.
- For manual test, keep Manual button pressed. **Do not** exceed 15 seconds at 375 amps, or load resistors may glow.

3.1.2 Battery Precaution

Connect the battery or power supply to the TI. Observe polarity.

Table 3 Tolerance Limits: 0.2V

TI Voltmeter	DMM Tolerance Limit
12.7 (example)	12.5 – 12.9 (± 0.2)

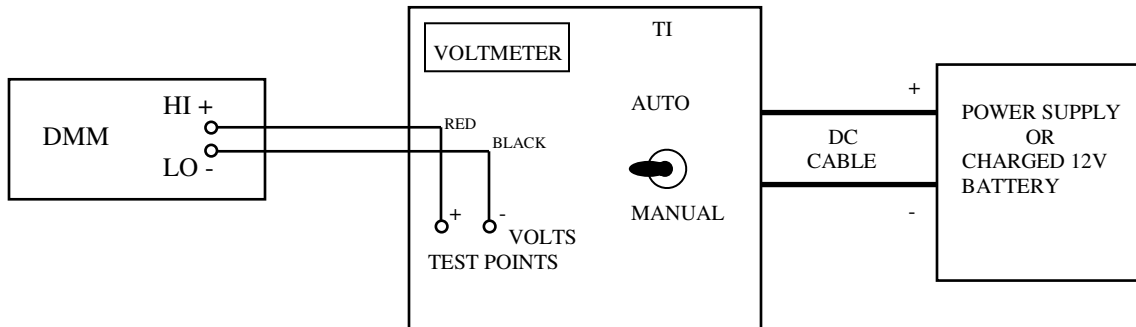

Figure 1 Voltmeter Test Setup

WARNING

HARMFUL CURRENTS AND VOLTAGES MAY BE PRESENT IN THE TI DC BATTERY CABLE LEADS.

SECTION 4 VERIFICATION PROCESS

NOTE: Unless otherwise specified, verify the results of each test and take corrective action whenever the test requirement is not met before proceeding.

4.1 Power Switch

Voltmeter tests when its power switch is set to OFF.

4.1.1 TI voltmeter reads battery or power supply volts.

4.1.2 Set the DMM to read DC volts.

4.1.3 Connect the DMM as shown in Figure 1.

4.1.4 Compare the reading of the DMM to the TI voltmeter. Per Table 3

4.1.5 LOAD CURRENT TESTS

Connect the equipment as shown in Figure 2.

4.1.6 Connect shunt as described in table 2 item 2.2 and power supply or optima battery as described in table 2 item 2.3

4.1.7 Set switch to Manual to obtain Readings. Load will not remain on over 15 seconds. Refer to table 5, par 4.1.16

AMMETER AND SHUNT TEST SETUP

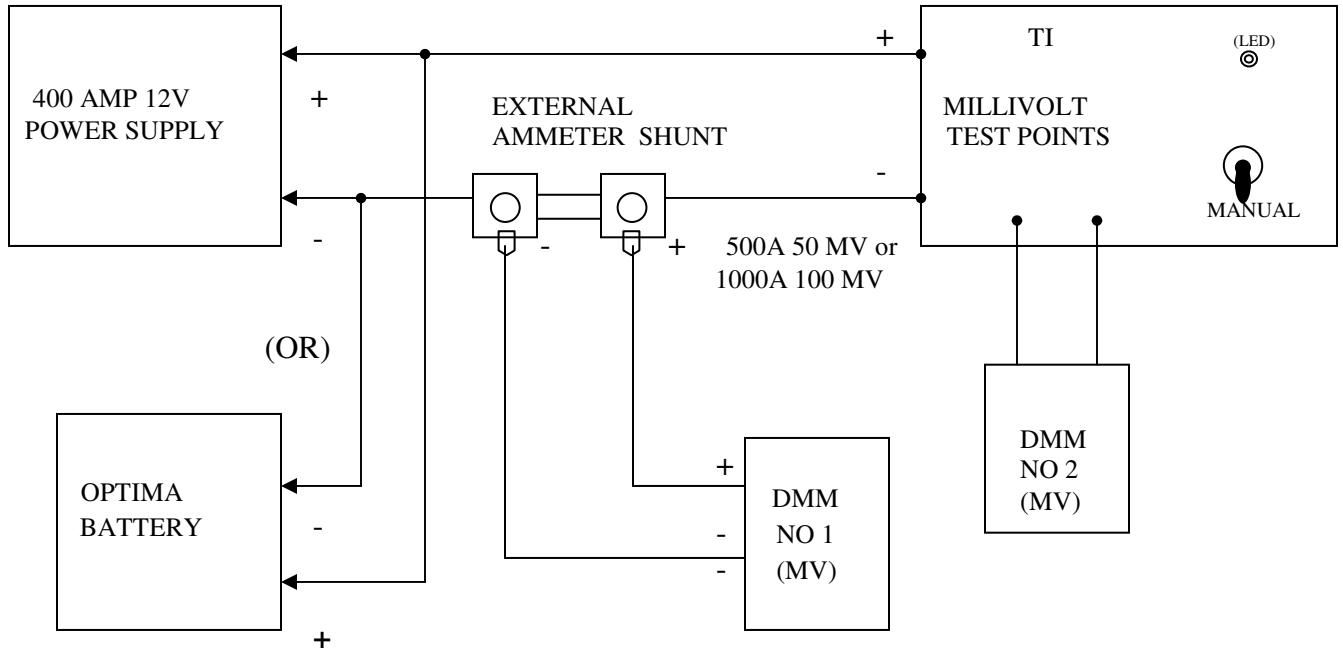

Figure 2 Ammeter Test Setup

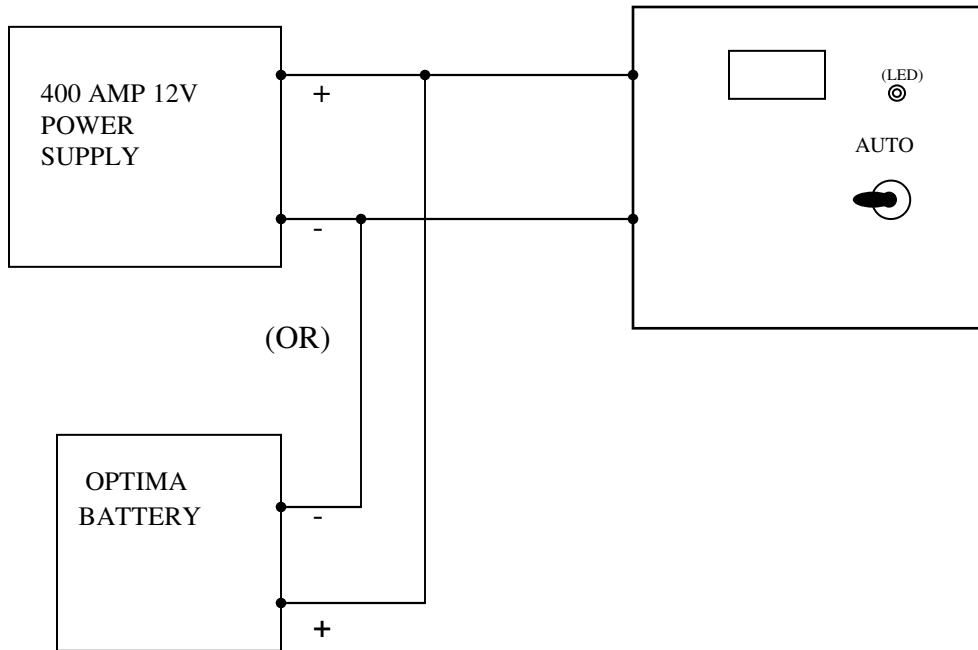

Figure 3 Timing Setup Test

- 4.1.8 TIMING TEST, Connect per Figure 3, refer to table 4 for tolerances.
- 4.1.9 Auto-Off-Manual Switch OFF.
- 4.1.10 Connect the TI to the Power Supply or Optima Battery.
- 4.1.11 Observe the stopwatch or timer. Simultaneously Set the stop watch or note the time and press the TI switch to “AUTO”.
- 4.1.12 Wait until after the end of 15 second time interval and verify the voltmeter holds (freezes) its voltage. Verify the load current drops to zero.

Table 4 Timing Requirements

TI	Time Tolerance Limit
“AUTO” test led ON Load ON	START
Voltmeter Holds Battery End Voltage Load contactor drops out	15 Sec Within 2 Sec

Summary Table of Tolerance Requirements

TI	TOLERANCE
4.1.14 Voltmeter	0.2 Volts
4.1.15 TI Internal Shunt and Panel Ammeter accuracy.	Ammeter Reading Verification: Within 15 Amps (Refer to paragraph 4.1.2, figure 2)
TIME	13-17 Seconds. Voltage reading holds. Load drops-out. Zero Ampere reading.

Parts List for Power Products ST-375 High Rate Discharge Tester

Item No.	Reference Designation Number	Quantity	Description
1	R1-6	6	Resistor, 0.2 Ohm 300 watt load
2	FAN1,2	2	Fan, 12 volt DC cooling
3	Shunt1	1	Shunt, 500 Amp 50 millivolt
4	C500,400	2	Capacitor, 4700 mfd. 16 volt
5	K500,400	2	Contact, Power
6	D1,2,3	3	Diode, relay shunt 1N4004
7	D4,5,6	3	Diode, blocking
8	BUSBAR1	1	Bus Bar, Copper
9	K1	1	Relay, N.O. & N.C. poles
10	SW1	1	Switch, Three position Momentary center off panel mounted
11	SW2	1	Switch, SPST panel mounted
12	SW3	1	Switch, Pushbutton NC panel mounted
13	VR1	1	Regulator, Voltage 5 volt output
14	TIMER1	1	Relay, Time Delay
15	VM1	1	Meter, Digital Volt panel mounted
16	AM1	1	Meter, Digital Current panel mounted
17	LED1	1	LED, Yellow
18	TP2,3	2	Jack, Test Points Pan Mounted - Red
19	TP1,4	2	Jack, Test Points Pan Mounted - Black
20	R7	1	Resistor, fixed 30 ohm 5 watt
21	R8	1	Resistor, fixed 330 ohm 1/8 watt
22	R9	1	Resistor, fixed 1 K ohm 1% toler. 1/8 watt
23	R10	1	Resistor, fixed 1 M ohm 1% toler. 1/8 watt