

POWER PRODUCTS MANUAL No. C25-805-1



TECHNICAL MANUAL
INSTRUMENT VERIFICATION PROCEDURES

12V BATTERY CONDITIONER / CHARGER

**POWER PRODUCTS
P/N C25C MODEL AC25C
NSN: 6130-01-539-5316**

MFD BY: POWER PRODUCTS, INC.
27 PAMARON WAY, SUITE E
NOVATO, CA 94949
CAGE CODE 3C8X4
www.power-products.com

TABLE OF CONTENTS

ILLUSTRATIONS List	2
TABLES List	2
SECTION 1 INTRODUCTION AND DESCRIPTION	3
Description	3
Procedure	3
Performance Parameter Test	3
Table 1 Verification Description	3
SECTION 2 EQUIPMENT REQUIREMENTS	4
Table 2 Equipment Requirements	4
SECTION 3 PRELIMINARY OPERATIONS	5
Preliminary Precautions & Setup	5
3.1 Avoid Damage from shorting	5
3.2 Connect to appropriate AC source	5
SECTION 4 VERIFICATION PROCESS	6
4.1 VOLTMETER Tests	6
4.1.1 Set Conditioner switch	6
4.1.2 Verify voltage reading	6
4.1.3 Set DMM	6
4.1.4 Connect DMM per figure	6
4.1.5 Compare DMM to Conditioner Panel Meter	6
Table 3 Tolerance Limits	6
4.1.5.1 VOLTMETER TEST	6
Figure 1	7
WARNING Current & Voltages	7
4.1.6 AMPERE METER TESTS	7
4.1.7 Set Switches	7
4.1.8 Test Setup per Table 2	7
Figure 2	7
Figure 3	8
4.1.9 Set DMM	8
Table 4.Tolerances	8
5.0 TESTING AND VERIFYING THE TEMPERATURE PLATE	9
TEMPERATURE PLATE TEST SETUP	9
Figure 4 Temperature Test Setup	9
Equipment Required Table 5.	9
5.1 Procedure Temperature Plate Test	10
Step One	10
Step Two	10

ILLUSTRATIONS LIST

Figure		Page
1	Voltmeter Test Setup.....	6
2	Ammeter Test Setup Option 1.....	7
3	Ammeter Test Setup Option 2.....	8
4	Testing & Verifying temperature Plate.....	8
-	Data Sheet C25C-8/05.....	11

TABLES LIST

Table		Page
1	Verification Description.....	4
2	Equipment Requirements.....	4
3	Tolerance Limits.....	6
4	Tolerance-Meter.....	8

SECTION 1 INTRODUCTION AND DESCRIPTION

Description

The C25C Conditioner / Charger is used in authorized military facilities and as described in the NAVAIR 17-15 BAD-1 Technical Manual, Appendix N. The unit is equipped with a battery temperature sensing plate which sits on top of the optima battery. The C25C de-sulfates and recovers sulfated batteries by connecting available voltage to a maximum of 21 Volts pulsed, to the terminals of the battery. The resulting pulsed current breaks-down the sulfate coatings on the battery plates. When sufficient breakdown is achieved, the C25C reverts to a smooth DC constant potential charge limited to approximately 14.8 Volts and 28 Amps maximum. The battery may be removed from the conditioner for charging from other sources, or can be left on the conditioner for the completion of charge.

The temperature plate continuously monitors battery temperature and cuts-off conditioning or charging power if the battery reaches approximately 113° F. This is necessary as the high pulsing process may cause some heating in batteries that were left in a discharged state for extended periods of time and have become extremely sulfated. The conditioning or charging procedures automatically re-continue when the battery cools down, to about 85° F. There are variations in the cut-off and restart temperatures depending on the length of time it takes to heat and cool the battery and hence the time the sensors imbedded within the plate take to reach their rated temperatures.

Procedure

This procedure describes the verification of accuracy of the Power Products Conditioner/Charger C25C. The C25C being verified is referred to herein as the TI (Test Instrument). The C25C operates from a standard AC source of nominal 120 volts 50/60 Hz. 8 Amps.

Performance Parameter Test

This procedure includes tests of essential performance parameters only. Any malfunction or out-of-limit readings noticed during these procedures, whether specifically tested for or not, should be referred to Power Products.

Table 1 Verification Description

TI Characteristics	Performance Specification	Test Method
Voltmeter	Range: 0 to 21 V Tolerance: 0.3 V	Compare to an external multimeter.
Ammeter w/TI internal shunt (OPTION 2)	Range: 0 to 28 A Tolerance: 0.4 A	Compare to an external multimeter.
Ammeter w/external shunt (OPTION 1)	Shunt / Ammeter combined tolerance 0.4A	Connect to external shunt and multimeter
Temperature Plate	Shuts off the unit at approximately 113°F (closure of contacts in the temperature plate) Re-continues operation at approx 85°F	Heat the temperature plate and monitor temperature with thermometer For shut-off test, allow to cool for re-continue operation

SECTION 2 EQUIPMENT REQUIREMENTS

NOTES

Minimum “use specifications” are the principal parameters required for performance of the verification, these figures are included to assist in the selection of alternate equipment, which may be used at the discretion of the maintenance facility. Satisfactory performance of alternate items shall be verified prior to use.

The instruments utilized in this procedure were selected from those known to be available at Naval, Marine Corps, and Air Force facilities and the listing by make or model number carries no implication of preference, recommendation or approval for use by other agencies. It is recognized that equivalent equipment produced by other manufacturers may be capable of equally satisfactory performance in this procedure.

Table 2 Equipment Requirements for TI (HEAT PLATE SEE SECTION 5)

Item	Minimum Use Specifications	Verification Equipment
2.1 Digital multimeter (DMM)	DC volts to 21V DC millivolts to 28MV	FLUKE 77AN
2.2 Ammeter shunt 1 Ampere per Millivolt e.g. 50Amp 50mv or 100Amp 100mv Shunt	Range: 0 to 50mV	Local Supply
2.3 Optima battery or load bank capable of 21V 16A 14.8V 28A	NA	Local Supply

SECTION 3 PRELIMINARY OPERATIONS

WARNING !

DO NOT REVERSE
BATTERY POLARITY
USE ONLY: RED CLAMP TO
POSITIVE (+)
BLACK CLAMP TO
BATTERY NEGATIVE (-)

NOTE: IF BATTERY IS REVERSED, THE AUTOMOTIVE TYPE MAXI-FUSE WILL BLOW. HOWEVER, THERE ARE POWER CAPACITORS AND ELECTRONICS WITHIN THE UNIT THAT MAY POSSIBLY BE DAMAGED BY A REVERSAL BEFORE THE FUSE BLOWS, THEREFORE USE CAUTION WHEN CONNNECTING THE BATTERY.

THE MAXI-FUSE MAY BE REPLACED WITH A STANDARD MAXI-FUSE OF 70 AMP RATING.

PLEASE CONTACT POWER PRODUCTS IF SPARE FUSES ARE NEEDED.

Preliminary Precautions & Setup

3.1 Avoid Damage from shorting

Ensure that power switch is set to off to avoid damage to the TI. Ensure that the alligator clamps are separated and secured so that short circuit does not exist when the TI is turned on.

3.2 Connect to appropriate AC source

Connect the auxiliary equipment and the TI to the appropriate power source. (120V 50/60Hz 10A)

SECTION 4 VERIFICATION PROCESS

NOTE: Unless otherwise specified, verify the results of each test and take corrective action whenever the test requirement is not met before proceeding.

4.1 VOLTMETER Tests

Voltmeter tests performed WITHOUT BATTERY or LOAD BANK CONNECTED.

4.1.1 Set Conditioner switch

Set switch on C25C, located at the bottom of front panel, to “ON” position.

4.1.2 Verify voltage reading

TI voltmeter reads approximately 21 Volts.

4.1.3 Set DMM

Set the DMM to read DC volts.

4.1.4 Connect DMM per figure

Connect the Digital Multi Meter as shown in Figure 1.

4.1.5 Compare DMM to Conditioner Panel Meter

Compare the reading of the DMM to the TI voltmeter. Per Table 3

Table 3 Tolerance Limits: 0.3V

TI Voltmeter	DMM Tolerance Limit
20.8	20.5 – 21.1
21.1	20.8 – 21.4

4.1.5.1 VOLTMETER TEST Performed WITH BATTERY, READING ONLY.

4.1.5.2 Set C25C switch to “OFF/RESET”

4.1.5.3 Connect battery which has some terminal voltage (over 6-7volts)

4.1.5.4 Connect per figure 1 compare DMM to the TI voltmeter. Tolerance limit 0.3V

Figure 1 VOLTMETER TEST SETUP

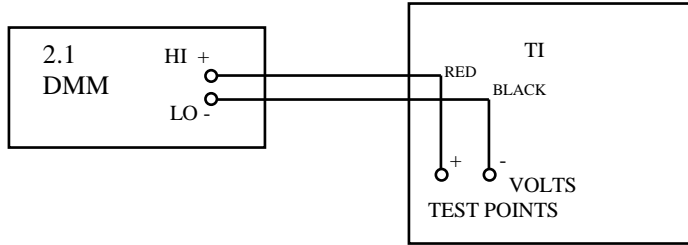

WARNING Current & Voltages

HARMFUL CURRENTS AND VOLTAGES MAY BE PRESENT IN THE TI DC BATTERY CABLE LEADS. THE TI ON/OFF/RESET SWITCH MUST BE SET TO THE OFF/RESET POSITION BEFORE CONNECTING OR DISCONNECTING THE TI DC BATTERY CABLE TO/FROM THE BATTERY.

4.1.6 AMPERE METER TESTS

Note: The TI ammeter is connected to an internal shunt in the TI. Shunts are large blocks of copper connectors and copper alloy resistor bars. They don't lose accuracy unless subjected to prolonged overload above 50 Amps, which the C25C is not capable of producing. Therefore 2 options are described. Option 1: Verifying TI shunt and ammeter. Option 2: Verifying the TI ammeter only with the TI's internal shunt.

Connect the equipment as shown in Figure 2.

4.1.7 Set Switches

Ensure that the ON-OFF/RESET switch is set to OFF/RESET

4.1.8 Test Setup per Table 2

Connect shunt as described in table 2 item 2.2 and resistive load or optima battery as described in item 2.3

Figure 2 AMMETER AND SHUNT TEST OPTION 1 SETUP

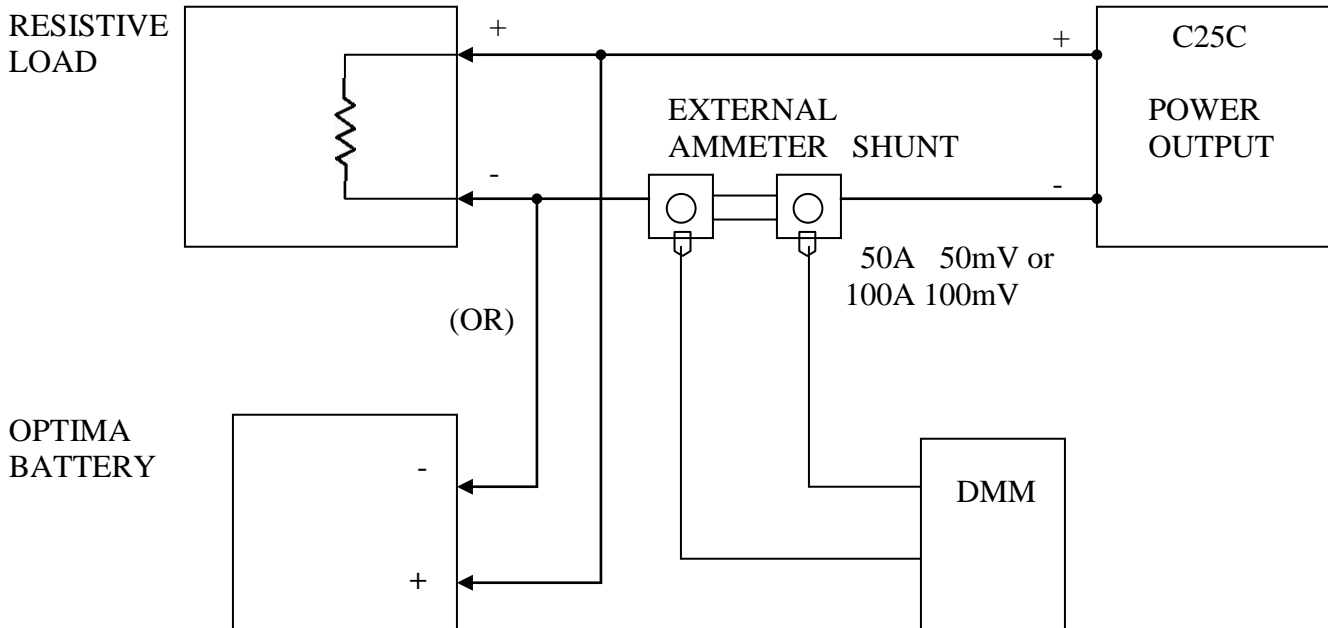
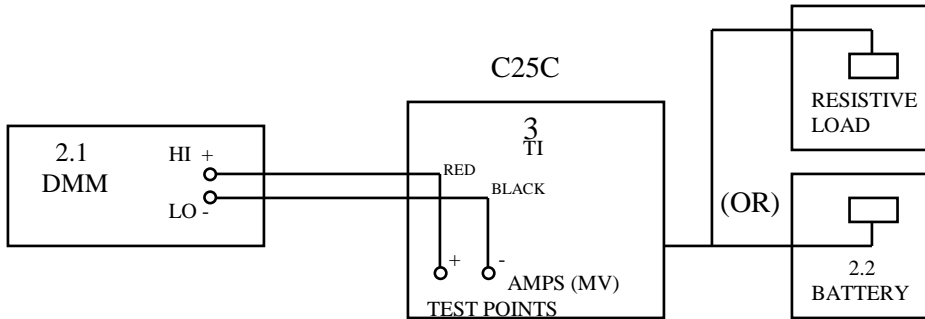

Figure 3 AMMETER TEST SETUP OPTION 2



4.1.9 Set DMM

Set the DMM to measure DC Millivolts and set the TI ON/OFF/RESET switch to ON

OPTION 1

Tolerance limit 0.4 Millivolts (amperes) external (shunt and TI ammeter)

Table 4.Tolerances

TI AMMETER	DMM TOLERANCE LIMIT
5.0 AMPERES	4.6 - 5.4 AMPERES
15.0 AMPERES (EXAMPLE)	14.6 - 15.4 AMPERES

5.0 TESTING AND VERIFYING THE TEMPERATURE PLATE.

Figure 4 TEMPERATURE TEST SETUP

TEMPERATURE PLATE TEST SETUP

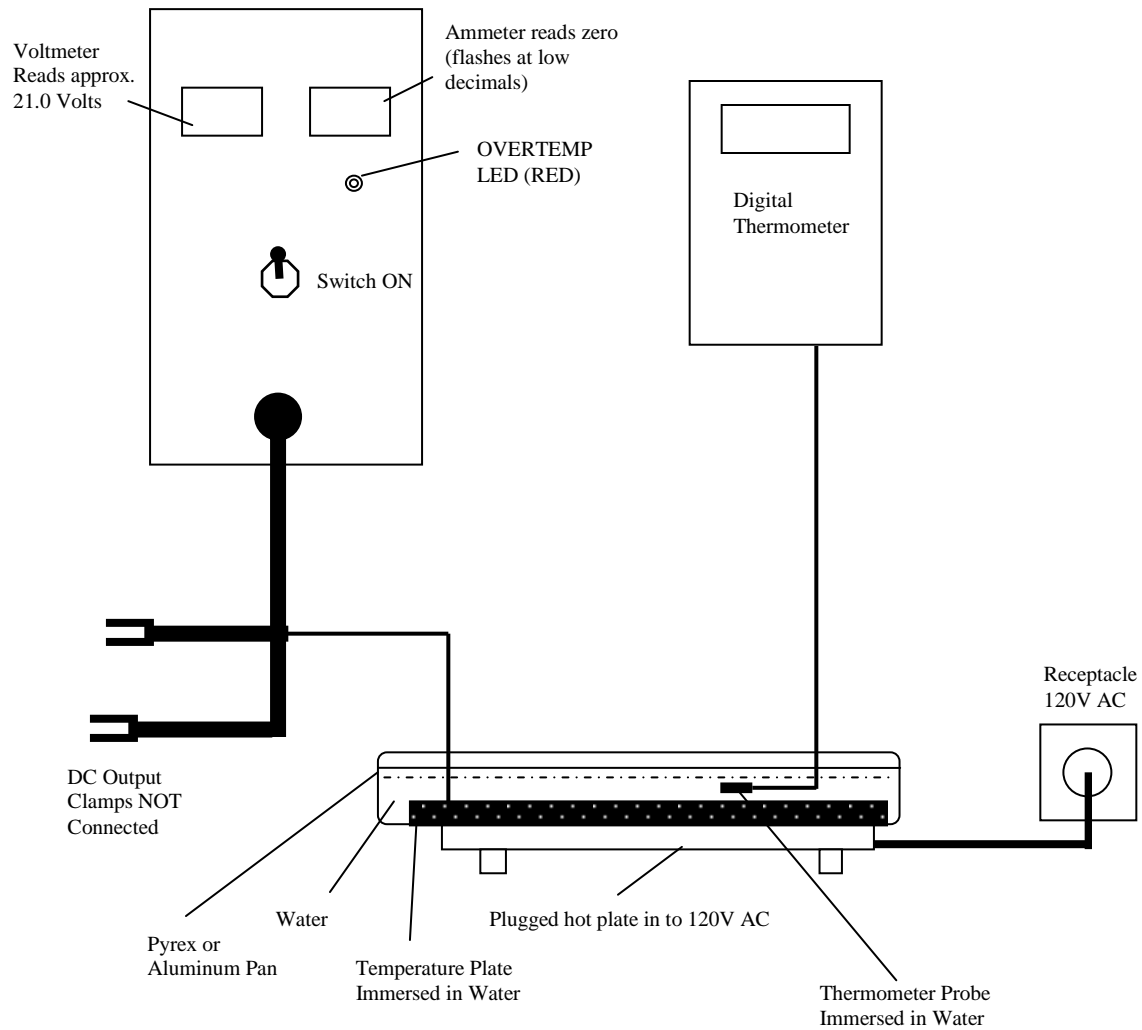

Equipment Required Table 5.

Hot Plate (standard consumer type) 115 V AC 750-1500W Pyrex or aluminum pan approx. 12x9x2 deep (standard consumer type)	Local Supply
Digital thermometer w/probe	Local Supply

5.1 Procedure Temperature Plate Test:

Step One

Turn hot plate setting to low for a slow heating. As water heats, observe the thermometer readout. At approx 113° F TI voltmeter and ammeter will turn-off and red "OVERTEMP" led will light. Tolerance: 105-121°F

Step Two

Turn switch off or disconnect hot plate. As water cools, observe thermometer temperature. At approx. 85°F TI voltmeter and ammeter reading restores, the red "OVERTEMP" led will turn-off. Tolerance 80°F - 90°F



Designer and manufacturer of aircraft lead-acid and nickel-cadmium battery support equipment since 1980. Headquarters and main plant located in Novato, California.

CONTACT INFORMATION:

POWER PRODUCTS, INC.

27 PAMARON WAY, Bldg. E NOVATO, CA 94949

PH: 415-883-6300 FX: 415-883-6302

WWW.POWER-PRODUCTS.COM